

4-Way Power Divider/Combiner

FPPD4-0-18000-R5-S

4-Way, DC~18GHz

Features:

- Small Size
- Low Insertion Loss

Applications:

- Amplifiers
- Mixers
- Antennas
- Laboratory Test

Electrical

Frequency:	DC~18Ghz
VSWR:	1.8 max.
Insertion Loss:	2.0dB max.
Isolation:	5.5dB
Amplitude Balance:	±1dB
Phase Balance:	±8°
Power @SUM Port:	0.5W as divider
Impedance:	50Ω

Mechanical

Size ^{*1}:	56*30*10mm 2.205*1.181*0.394in
Connectors:	SMA Female
Mounting:	4-Φ2.2mm through-hole

[1] Exclude connectors.

Construction

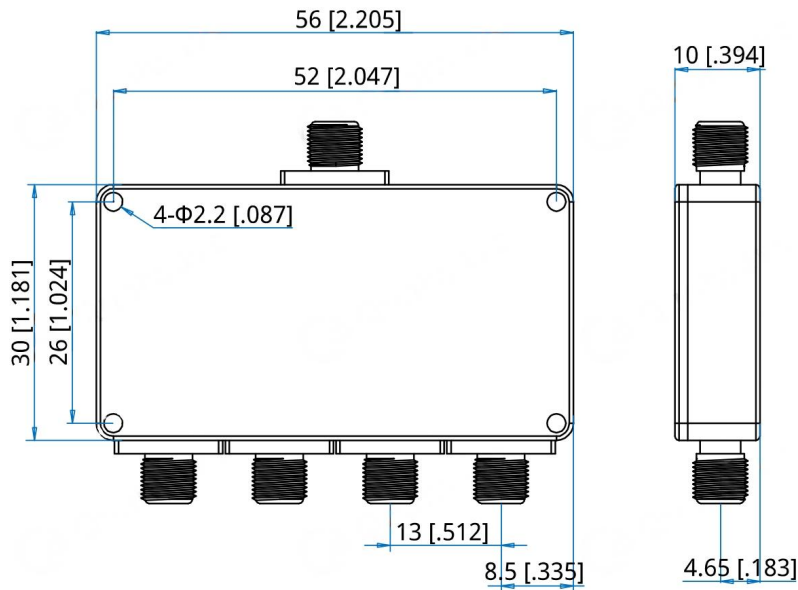

Note(s)

Unit: mm [in]

Tolerance: ±0.5mm [±0.02in]

Performance Curves

Input VSWR vs. Frequency

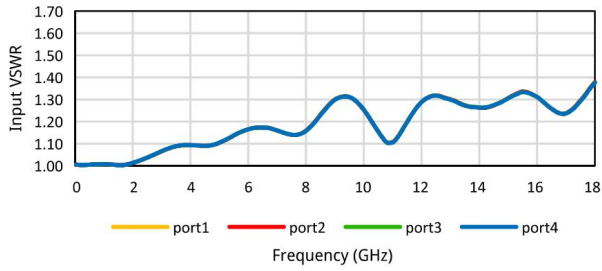

Output VSWR vs. Frequency

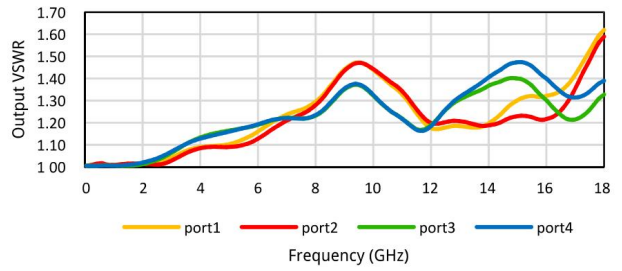

Insertion Loss vs. Frequency

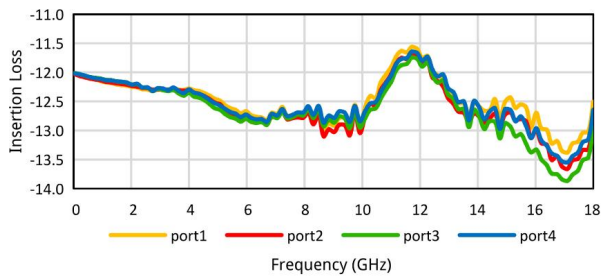

Isolation vs. Frequency

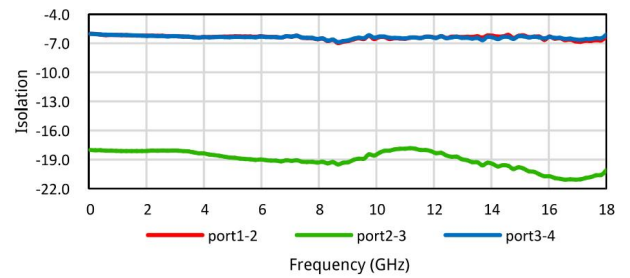

Amplitude balance vs. Frequency

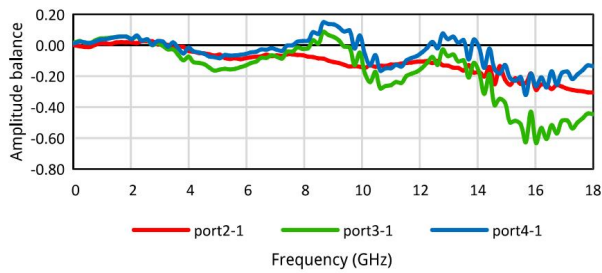

Phase balance vs. Frequency

