

## Coaxial Adapter

### FPAA1N

1-5/8" (IF70) to N

**Features:**

- Low VSWR

**Applications:**

- Wireless
- Transmitter
- Laboratory Test
- Radar

#### Electrical

**Frequency:** DC~3GHz

**VSWR:** 1.1@DC~1000MHz max.

**Dielectric Withstanding Voltage:** 6000V RMS, 50Hz,  
at sea level, min.

**Working Voltage:** 2100V RMS, 50Hz,  
at sea level, max.

**Impedance of Dielectric:** 5000MΩ min.

**Impedance of Contact (Center):** 1.5mΩ max.

**Impedance of Contact (Outer):** 1.5mΩ max.

**Average Power:** 3.4KW@900MHz

**Peak Power:** 90KW max.

**Impedance:** 50Ω

#### Mechanical

**RF Connectors:** 1-5/8" (IF70)  
N

**Mating Life Cycle:** 100 cycles min.

**ROHS Compliant:** Full ROHS compliance

**Outer Conductor:** Nickel plated brass

**Dielectric:** PTFE

**Inner Conductor:** Silver plated phosphor bronze

**Gasket:** Silicone rubber

#### Environmental

**Temperature:** -55 ~ +85°C

#### Construction

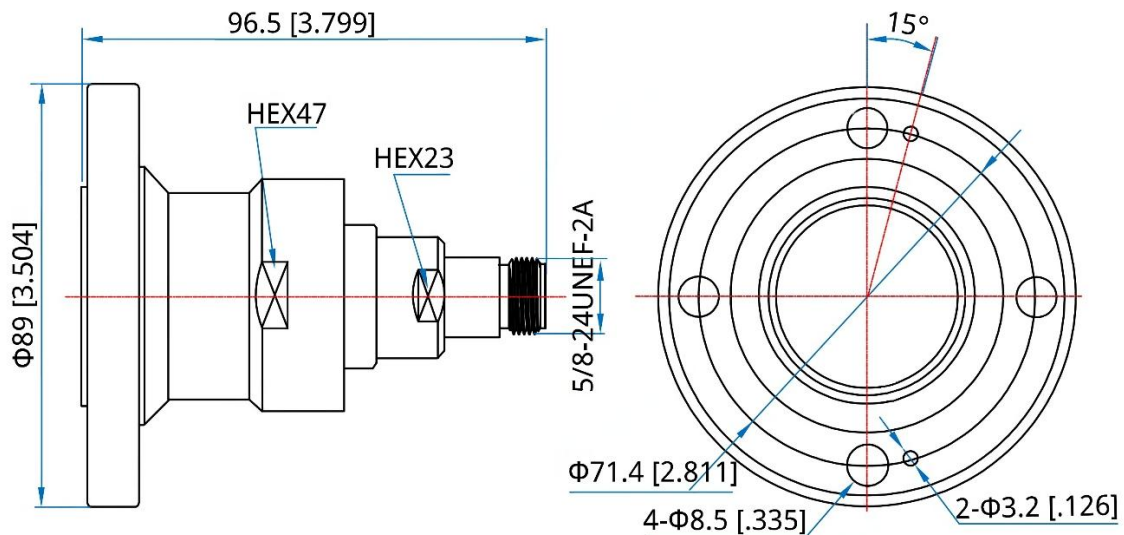

**Note(s)**

Unit: mm [in]

Tolerance: ±0.2mm [±0.008in]